



SAS FREYSSINET PRODUCTS COMPANY
ZA DU MONAY - BP 18
71210 SAINT EUSEBE France
Tel. +33.3.85.73.69.00

FREYSSINET PRODUCTS CO.

PRODUCT DESCRIPTION

Geotechnics
Freys500-E
permanent grounds
anchors

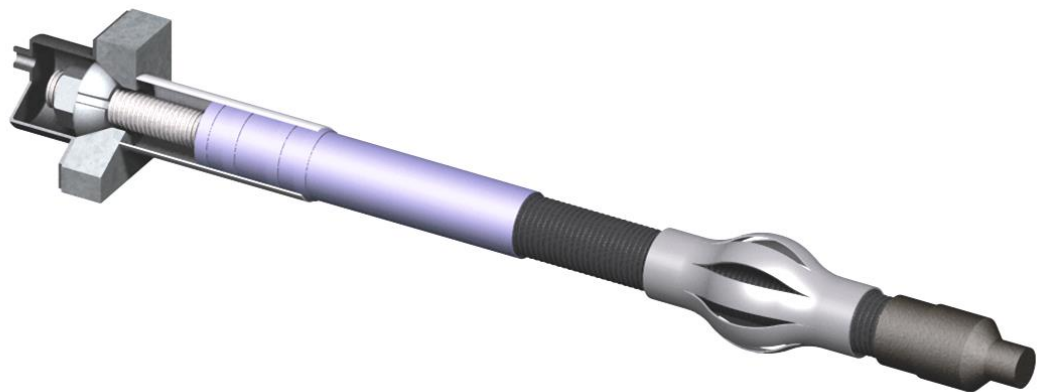

Ref: BGT-011
Revision: 0
July 2017



FREYSSINET
SUSTAINABLE TECHNOLOGY

COPYRIGHT

This document is the exclusive property of FREYSSINET.

It is confidential and may not be used, reproduced or communicated either in whole or in part, in any form or manner without the prior written agreement of FREYSSINET. All drawings and pictures aren't contractual.

REVISION INDICES FOLLOW-UP TABLE

Rev	Date	Modification	Prepared by	Checked by	Approved by
0	21/07/17	First issue	C. GAUCHERAND	F. ROBERT	E. TIBOEUF

TABLE OF CONTENTS

1. INTRODUCTION.....	1
1.1. Scope of the document.....	1
1.2. Geotechnics.....	1
1.3. Ground anchors scope of use.....	2
1.4. Design.....	3
1.5. Manufacturing.....	3
1.6. Installation.....	3
1.7. Surveillance.....	3
2. APPLICABLE DOCUMENTATIONS.....	4
2.1. Specific documentation.....	4
2.2. Standards for components.....	4
2.2.1. Bars Freyssi500-E.....	4
2.2.2. Accessories.....	4
2.3. Standards for manufacturing.....	4
2.4. Standards for control.....	5
3. DESCRIPTION OF THE FREYSSI500-E PERMANENT ANCHOR.....	6
3.1. Overview.....	6
3.2. Bars.....	7
3.3. Anchor body.....	8
3.3.1. Extra length.....	8
3.3.1. Bond length.....	8
3.3.2. Free length.....	8
3.3.3. Prefabricated elements.....	9
3.4. Anchor head.....	10
3.5. Coupling.....	10
3.5.1. On bond length.....	10
3.5.2. On free length.....	10
4. MANUFACTURING.....	11
4.1. Site of production & distribution.....	11
4.2. Manufacturing process.....	11
4.2.1. Products incoming inspection.....	11
5. INSTALLATION ON SITE.....	12
5.1. Preparation of the anchors.....	12
5.2. Drilling.....	12

5.3.	Installation of the anchors	13
5.4.	Grouting	14
5.5.	Installation of the anchor head	14
5.6.	Stressing-testing	14
5.6.1.	Proving test	14
5.6.2.	Suitability test	15
5.6.3.	Stressing & acceptance test	15
6.	QSE	16
6.1.	Quality - ISO 9001	16
6.2.	Safety - OHSAS 18001	16
6.3.	Environment – ISO 14001	16
6.4.	Quality documentation	17

1. INTRODUCTION

1.1. Scope of the document

This document is intended to describe the product in term of design, manufacturing and inspection.

1.2. Geotechnics

The Freyssinet Group is the world leader in specialized civil engineering, working in two fields : structures and soil. The soil activities include ground anchors, soil nails, rock bolts, micropiles and port tie-rods. As part as these activities, Freyssinet supplies Freyssi500-E Permanent Anchors.

The Freyssinet Group is organized in geographical zones around the world with strong local roots, with 70 bases in more than 50 countries. It is a subsidiary of Vinci Construction, world leader in construction and associated services, which combines almost 2,500 companies in more than 100 countries all around the world.

The Freyssi500-E Permanent Anchors developed by Freyssinet are designed to answer several standards and world normative requirements but also the environmental requirements specific to this type of product. FPC is the industrial branch of the Freyssinet Group and its headquarters are located in St. Eusèbe (France), from where the manufacturing of Freyssinet products (pre-stressing, stay cables, bridge fittings, geotechnical products, etc.) is organized and controlled.

To cope with the increasing demand of all the Freyssinet subsidiaries in the world, FPC has developed an important network of production facilities all over the world, implementing the same Quality Control System worldwide, in accordance with International Quality Standards.

As a result of this group strategy of procurement network, the Freyssinet subsidiaries have improved their services worldwide, and offer flexible and reactive solutions to their clients' needs.

1.3. Ground anchors scope of use

The Freyssi500-E Permanent Anchors are mainly used for stabilization of slopes, retaining walls and anchorage of structures.

Developed by Freyssinet, the Freyssi500-E Permanent Anchor is made of Freyssibar and its associated anchorages and couplings.

The typical cases are detailed below:

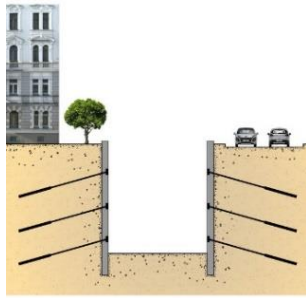

Excavation

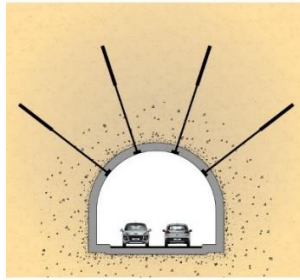

Tunneling

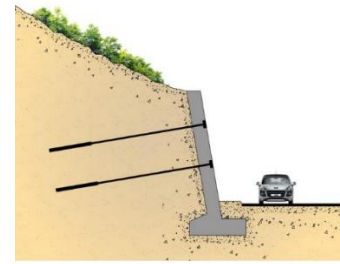

Slope stabilization

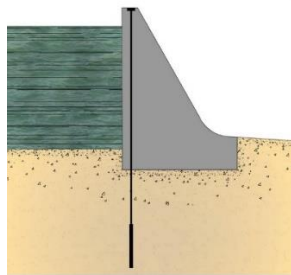

Dams

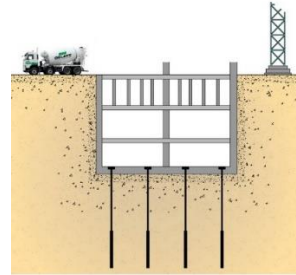

Hydrostatic uplift loads

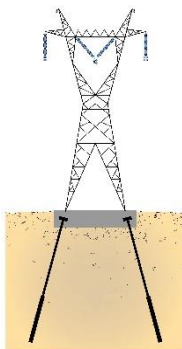

Pylons

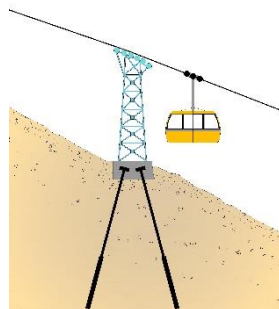

Cable cars

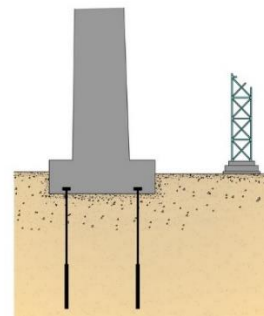

Wind mills

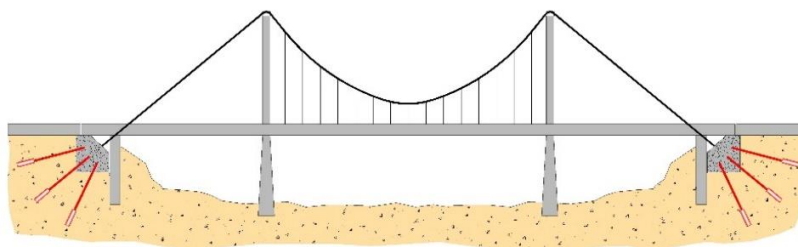

Suspended bridges

1.4. Design

The Freyssi500-E Permanent Anchor system complies with EN1537. The design is specific to Freyssinet. It can be adapted upon request.

1.5. Manufacturing

As Freyssi500-E Permanent Anchors are manufactured by Freyssinet, all customers will receive the same level of excellence and quality in the products and services. This complete control over our products and systems means that we can adapt our solutions to a wide range of applications and extreme operating conditions.

1.6. Installation

Installation is generally carried out by the customer. Special attentions are detailed in chapter 6.

1.7. Surveillance

Like any other system, the surveillance must be defined by the contractor depending on the scope of use.

Also, the anti-corrosion protection guarantees durability.

A monitoring of the anchors is generally installed, according to the Freyssicell technical data sheet:

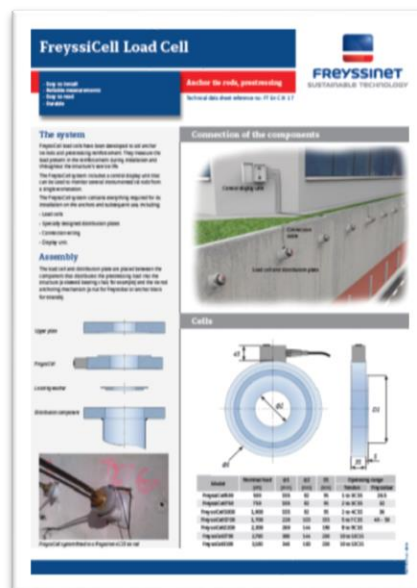

2. APPLICABLE DOCUMENTATIONS

2.1. Specific documentation

The use of the Freyssi500-E Permanent Anchor is inseparable from the following documentation (last version):

- Internal Technical Specification : GB500E-SPA-001
- EN1537: Execution of special geotechnical work – Ground anchors

2.2. Standards for components

FPC has analyzed all standards in order to satisfy the specific requirements of each norm. FPC uses the same equivalent material standard when it's possible in order to optimize the price of raw material. The system complies with geometrical, mechanical and technological requirements as defined by most of the relevant national and international standards.

2.2.1. Bars Freyssi500-E

Designation	Applicable standard	Material
Bars	EN 10080	Steel for the reinforcement of concrete

2.2.2. Accessories

Designation	Applicable standard	Material
Bearing plates	EN10025	Grade S235 flame cut or cold sheared
Plastic caps	Freyssinet Specifications	30% glass fiber reinforced PA 6
Nuts	EN 10293	Grade G42CrMo4 + QT2
Couplers	EN 10293	Grade G42CrMo4 + QT2

2.3. Standards for manufacturing

Designation	Applicable standard
Geometrical characteristics (when not mentioned) (bars & accessories)	Drawings
Mechanical & Chemical characteristics (bars)	EN10025
Mechanical & Chemical characteristics (accessories)	EN 10293

2.4. Standards for control

Designation	Applicable standard
Visual examination of welds	ISO 8501-3 / EN ISO 5817
Characteristics of the bars	EN 15630-1
Mill certificates for bars, nuts and couplers	Certificate 3.1 according to EN10204

3. DESCRIPTION OF THE FREYSSI500-E PERMANENT ANCHOR

3.1. Overview

The system is called "Freys500-E Permanent Anchor". The anchor body and the anchor head components are coming from the Freys500-E system. The corrosion protection of the anchor body consists of a corrugated sheathing, filled with cement grout at the factory. On the free length (if there is), the corrugated sheath is covered with a smooth duct. This insures a perfect corrosion protection of the ground anchor.

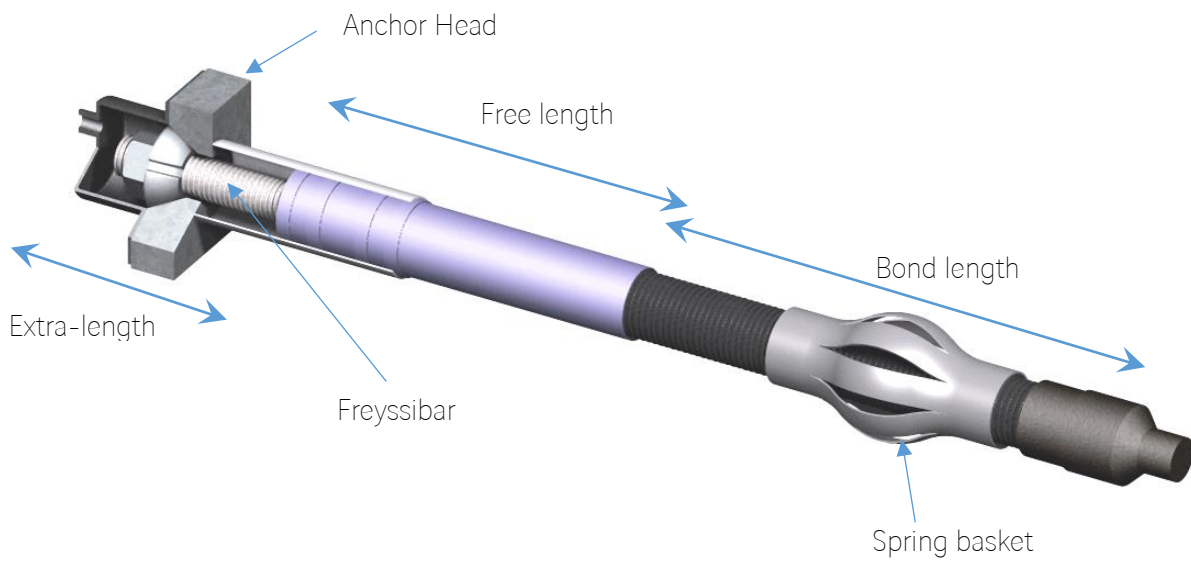

3.2. Bars

The bar Freyssi500 is a hot laminated bar. It includes ribs forming a thread on the whole length, which enables the screwability of the accessories at any point. The bar Freyssi500 is weldable like a reinforcement bar.

The rugged left hand thread is characteristic of the bar Freyssi500-E. The standard range includes nominal diameters below.



		16	20	25	28	32	40	50	63,5
Steel grade	MPa	500/550	500/550	500/550	500/550	500/550	500/550	500/550	550/700
Cross section area	mm ²	201	314	491	616	804	1256	1960	3167
Linear Mass	kg/m	1.61	2.47	3.85	4.83	6.31	9.86	15.41	24.86
Maximum diameter	mm	18.00	22.40	27.90	31.20	36.00	44.20	55.60	67.80
Characteristic value of maximum Force : Fpk	kN	110	172	270	339	442	691	1078	2217
Characteristic value of 0.1% proof force : Fp0.1%	kN	101	157	246	308	402	628	980	1758
Thread pitch	mm	8	10	12.5	14	16	20	26	21
Average Young modulus	GPa	200	200	200	200	200	200	200	200
Minimum elongation at break (A%)	%	10	10	10	10	10	10	10	10

3.3. Anchor body

The bars are delivered already encapsulated in a corrugated sheathing full of cement grout. The ground anchor can be made of one single element or several elements, connected together with couplers. The layout, including the length of each element, must be defined before delivery:

3.3.1. Extra length

On the anchor head area, clearance, without any protection, shall be provided to allow the installation of the nut and the stressing operation. This clearance is called extra length.

3.3.1. Bond length

The bond length consists of FREYSSI500-E bar, covered by a cement grout, approved for the anticorrosive protection of prestressing steels. This cement is itself contained in a sealed corrugated sheath. During tensioning, the stresses induced in the bar are transmitted to the protective grout, then to the grout and to the ground, after having passed through the corrugated sheath ribs.

In order to guarantee a minimum 5 mm cement coating on the inside of the sheath at all points of the reinforcement, a polyethylene rod with a diameter of 6 mm is placed as a helix around the bar. The minimum 10 mm sealing grout coating around the ground anchor is ensured by trough spacers placed every 2 meters.

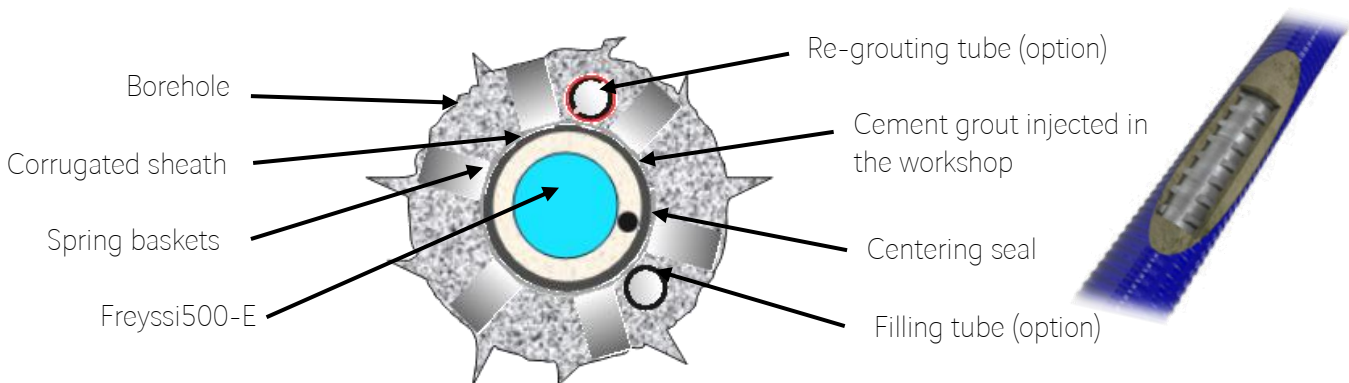

3.3.2. Free length

In the free length, the FREYSSI500-E bar is protected exactly as in the bond length. A smooth sheath is used to cover the corrugated sheath in order to guarantee the longitudinal movement of the ground anchor. When the bar is stressed, it can extend freely, resulting in micro cracking of the cement grout contained in the corrugated sheath. Since micro cracks have a very small width, the anti-corrosion protection of the bars is perfectly ensured.

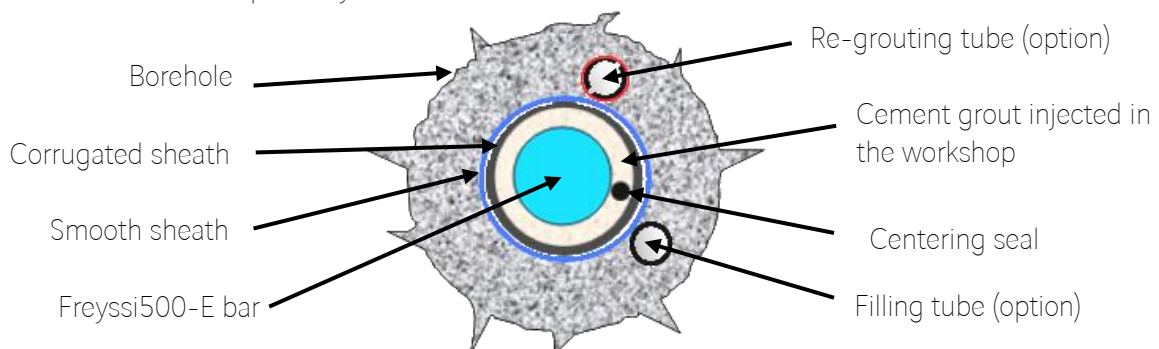

3.3.3. Prefabricated elements

The customer must define all the single elements of the anchor body among the proposed solution below:

Single element

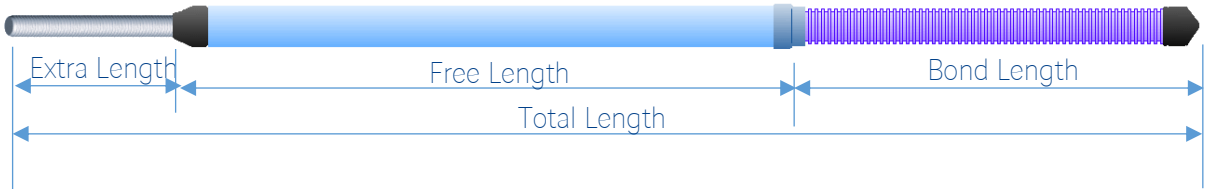

Foot element

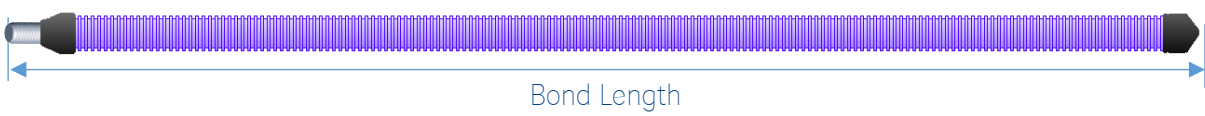

Head element



Middle element with bond length

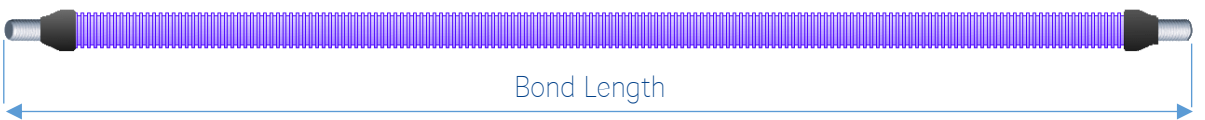

Middle element with free length

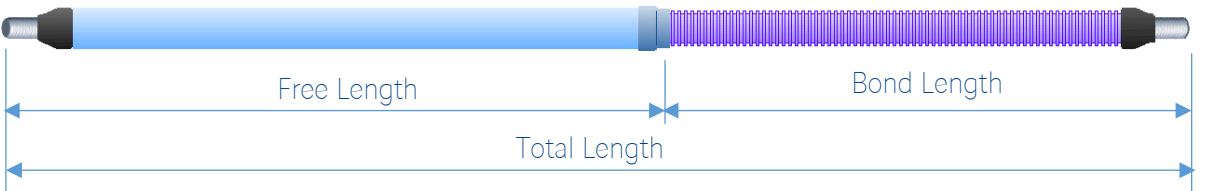

3.4. Anchor head

The anchor head is made of a bearing plate including a trumpet tube, a spherical nut, and a plastic cap. The trumpet and the cap are filled with a petroleum wax in order to ensure the corrosion protection of this area.

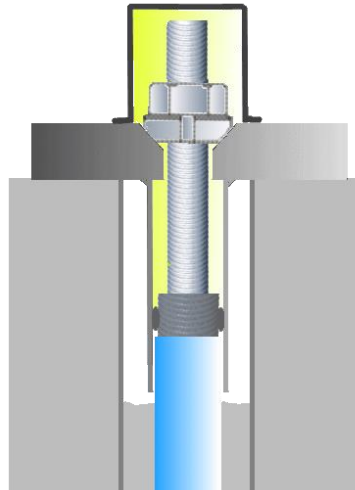

3.5. Coupling

The coupling is used for connecting the prefabricated elements of the anchor. The length of every single element is limited at 11,80 m (for freight by container), and can be reduced in difficult installation conditions.

3.5.1. On bond length

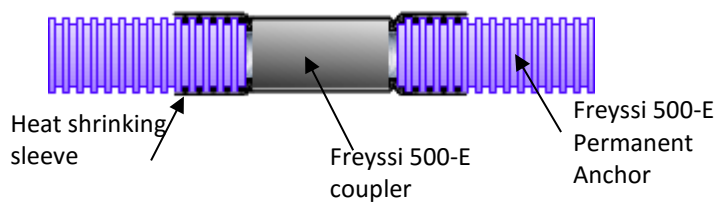

On the bond length, the corrosion protection of the coupling is done by a special heat shrinking sleeve. It insures the corrosion protection and the bonding of the tendon on this area

3.5.2. On free length

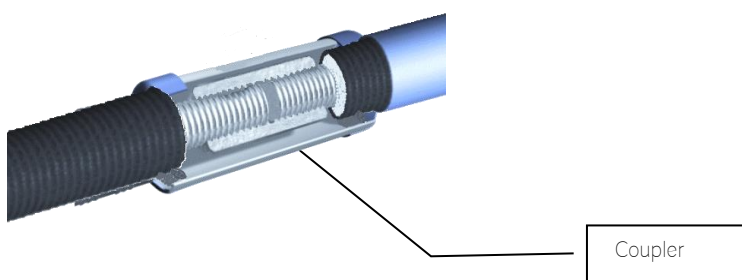

4. MANUFACTURING

4.1. Site of production & distribution

The bars and anchorage are manufactured in Czech Republic. Then, the bars are stored and transformed to become prefabricated bars at Freyssibar Center, in France.



4.2. Manufacturing process

4.2.1. Products incoming inspection

The bars and accessories are received at the Freyssibar Center in France. All mill certificates are checked and recorded.



5. INSTALLATION ON SITE

5.1. Preparation of the anchors

The elements of the anchor body must be prepared before the introduction in the borehole. They have to be installed on trestles, well designed to support the weight according the applicable calculation rules. A minimum of 1 trestle every 2 meters is required.

The spring baskets are installed around the corrugated sheathing and correctly fixed with a wire. The link must be done only on the side "end of hole" in order to allow the spring basket to fulfill its function "spring".

The injection system is also fixed around the anchor with wires or adhesive tape.

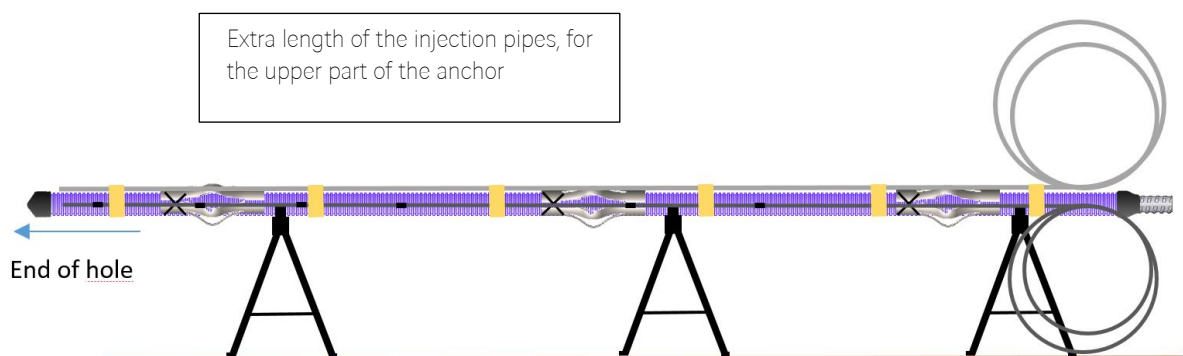

5.2. Drilling

The drilling operation is done by the main contractor. The following requirements must be fulfilled:

1. The deepness of the bore hole should allow the introduction of the anchor. If necessary, an over drilling of 0,5 or 1 meter can be done to ensure that the available length is enough, even if cuttings are falling to the bottom.
2. The diameter should allow the introduction of the anchor with the injection pipes and a final grout cover of 10 mm minimum. If a casing is used, its internal diameter must be considered to check the possibility of installation of the anchors.
3. The borehole should not collapse from the time of the drilling to the time of injection. If the ground is too loose, a dense injection fluid can be used (bentonite, cement grout, foam, mud) or a casing hole method can be adopted (ODEX, OD, TUBEX, ...).

5.3. Installation of the anchors

This operation is done by the main contractor. The adapted and safe lifting equipment must be used. The foot of the anchor is guided in the borehole and the top end is lifted up (1). Then the anchor is progressively introduced in the borehole.

When the first element is introduced, it must be maintained with a strap and a wedge system, to avoid it to fall to the bottom of the hole.

The following element is lifted up and connected to the previous one with a coupler (2). The corrosion protection of the coupler must be installed prior the assembling. On the bond length, the coupler is protected with the heat shrinking sleeve, which is retract with a hot air blower or a blowtorch (low flame):



During introduction of the anchor, the injection pipes are progressively guided by hand and fixed on the anchor with adhesive tape.

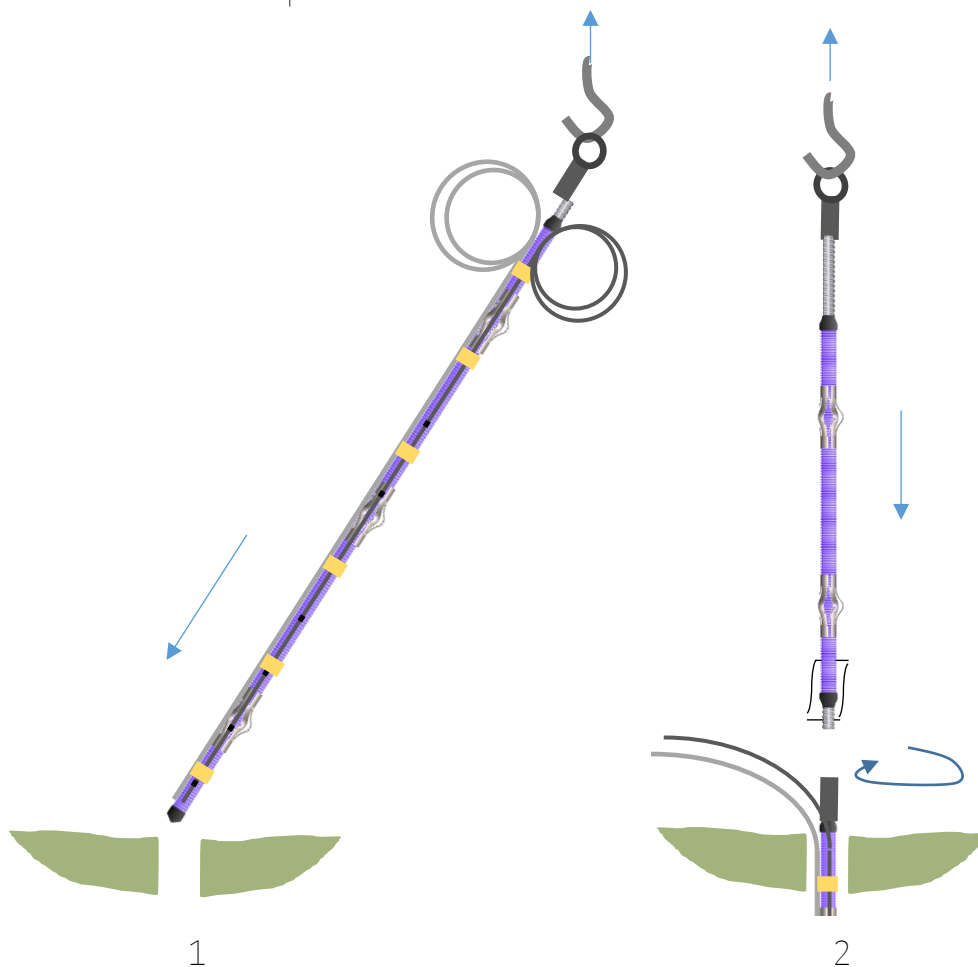

Special attention:

The coupler must be screwed half and half on the two bars to be connected. To insure its good position, the following precautions must be exercised:

- Mark the bars on a distance of 1/2 length of the coupler
- Glue the coupler in the bar with a fast hardening glue (e.g. cyanoacrylate glue)
- After assembling, control of the position of the coupler with the marks

5.4. Grouting

This operation is done by the main contractor.

The injection process should allow a good filling of the borehole and should allow to obtain the required resistance of the bonding of the anchor in the ground.

On the top of the borehole, the cement grout should be correctly stopped in order to allow a good installation of the anchor head.

When the injection is finished, the extra length of injection pipes must be cut off and removed.

5.5. Installation of the anchor head

A control of the surfaces is done prior to any installation. If necessary, a mortar is made to insure a good bearing surface between the plate and the structure.

The sealing is installed on the corrosion protection of the bar

The trumpet tube of the plate is filled at 2/3 of wax

The bearing plate is installed

The nut is screwed on the bar

After stressing, the cap is installed and filled with wax.

5.6. Stressing-testing

All the testing and stressing operations must be done according the applicable norms and specifications. According to EN 1537, the following tests must be done:

- 2 proving test on "lost" anchors
- 3 suitability tests on permanent anchors
- 1 acceptance test on each permanent anchor

5.6.1. Proving test

This test is done according "Step method", §9.4.1.c) of the EN 1537

The load applied on the anchor during the test is minimum $1,5 \times$ estimated resistance of the bonding

The tendon size and the bond length of the tested anchors will be chosen in order to ensure that $0,9 \times T_{p0,1} >$ test load

The load will be applied in 9 steps of 1 hour duration

These tests will be done prior to permanent anchors works

5.6.2. Suitability test

This test is done according "Step method", §9.4.1.c) of the EN 1537
The load applied on the anchor during the test is minimum $1,25 \times$ Service load
The load will be applied in 5 steps of 1 hour duration

5.6.3. Stressing & acceptance test

During stressing, each anchor will be tested at $1,25$ Service load.

6. QSE

The quality assurance system in force in the factory supplying the ground anchors units shall comply with, or be equivalent to, the standard ISO 9001: 2008.

6.1. Quality - ISO 9001

FPC is certified since September 1997 (according to successive standards as ISO 9002 v94 and ISO 9001 v2000). Since the renewal audit of September 2009, the company is certified ISO 9001 v2008. Manufacturing, sale and trade of structure equipment (road expansion joints, bearings and seismic protection devices) and components for cable stays and concrete prestressing. Trade of products for structure reinforcement.

6.2. Safety - OHSAS 18001

FPC is certified OHSAS 18001 v 2007 since April 2011.

6.3. Environment – ISO 14001

FPC is certified ISO 14001 since October 2010



6.4. Quality documentation

Different levels of quality documentation can be proposed (level 0, 1 or 2). The level of the quality documentation has to be determined at the beginning of the project. Each level includes the following documents:

Item	Documentation	Level 0	Level 1	Level 2
General Documentation	Delivery bill Certificate of conformity	X	X	X
Bars	Steel material certificate 3.1	-	X	X
Nuts and couplers	Steel plates material certificate 3.1	-	X	X
Final control	Geometrical control report of the prefabricated elements	-	-	X
Cement grout control	Cement grout production control	-		X

All documents can be shown during an audit.